

# SmartMaster

Art. No.: 64 310



## Applications

- Suitable for all materials, including high-alloy steel
- Low amounts of smoke/dust
- Occasional use

## Benefits

- Increased safety due to filter monitoring
- Flexible use due to hose connection

## Properties

- W3/IFA certified
- Handle with cable holder

## Technical Data

<b>Filter</b>	
Filter stages	3
Filter method	Storage Filter
Filter surface	13 m <sup>2</sup>
Type of filter	Filter cassette
Filter material	Non-woven fibre
Filter efficiency	> 99.5 %
Filter class	E12
Additional filters	Two pre-filters
<b>Basic data</b>	
Extraction capacity	950 m <sup>3</sup> /h
Weight	71 kg
Motor power	1.1 kW
Power supply	1 x 230 V / 50 Hz
Rated current	6.7 A
Control voltage	230 V, AC
Noise level	72 dB(A)
<b>Additional information</b>	
IFA-Certification	W3-Approved
Fan type	Radial fan
Quantity of extraction hoses	1
Diameter Extraction hose	150
Length extraction hose	3 m

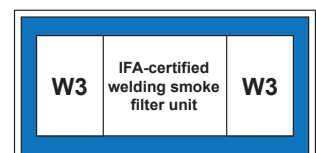

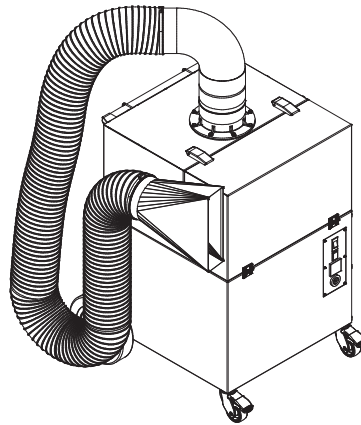
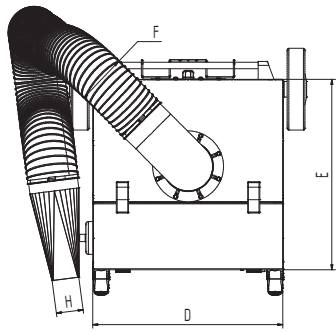
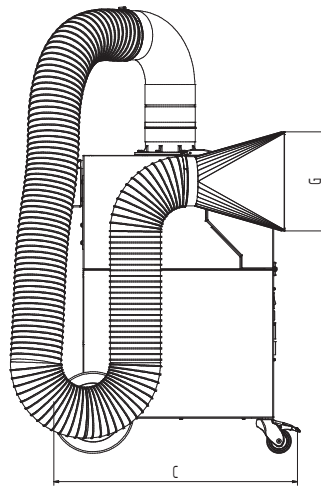
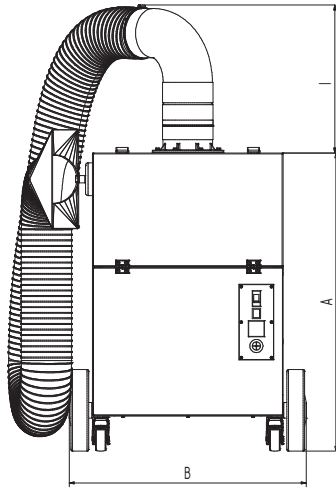

## Technical Data

### Dimensions

A	909 mm
B	722 mm
C	753 mm
D	580 mm
E	580 mm
F	150 mm
G	300 mm
H	80 mm
I	450 mm